

## Requirements

- Air circulation, dust levels, temperature, relative humidity and gas concentrations must be kept within limits which are not harmful to the animals
- All new buildings should be designed with the animals' comfort in mind, with the aim of preventing respiratory diseases. The buildings should provide enough ventilation throughout the year for the type, size and number of stock to be housed in them
- Where the ventilation in existing buildings is not good enough, they should be adapted by improving air inlets and outlets, or by using mechanical equipment
- When removing slurry from under slats, take special care to avoid fouling the air with dangerous gases which can harm both humans and animals.

### 13.1 Natural Ventilation

Correct building design is critical to ensure adequate ventilation. This is extremely important to maintain air quality.

To ensure adequate ventilation, it is important that the building is designed to:

- Remove excess heat
- Remove excess water vapour
- Remove microorganisms, dust and gases
- Provide a uniform distribution of air
- Provide correct air speed for stock.

Natural ventilation is the least troublesome, most efficient and least expensive system for providing an optimum environment within a building. The aim of

the ventilation system must be to provide a continuous stream of fresh air to every housed animal at all times of the day or night.

### Think about

Buildings will naturally ventilate best when they are sited at right angles to the prevailing wind direction.

In the UK, wind speed is above 1m/sec for more than 95% of the time. This means that for the majority of time, there is sufficient generating force to provide the necessary air changes within a building by natural ventilation. For the remaining time, the building relies on the stack effect to replace foul air with fresh air.

Heat produced by the livestock naturally rises. If it is unable to exhaust from the building at the highest point (at the ridge), it will condense and remain within the building, causing humidity to increase. As the air cools, it will fall back onto the bedding, increasing the moisture content and creating a suitable environment for bacteria to thrive.

If the warm air is able to exhaust from the ridge of the building, this draws fresh air into the building through the side inlets, ie the 'stack effect'. However, if there are insufficient air inlets, warm air cannot escape from the building as a vacuum effect will not be created.

### 13.2 Outlet ventilation

There are a number of methods to achieve adequate outlet ventilation which includes various ridge designs or a slotted roof. These are illustrated in Figures 13.a, 13.b and 13.c.

It is essential that there are adequate outlets in the ridge of the building. An open ridge is generally between 0.2-0.3m wide and should be unrestricted.

## ! Think about

Using upstands, as shown in Figures 13.a and 13.b, will improve ventilation rates and keep most of the rain out.

Figure 13.a – Open ridge

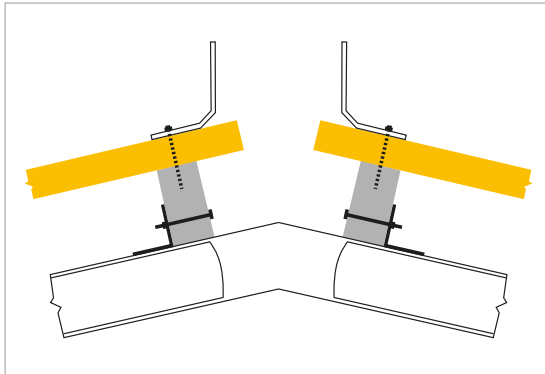

Figure 13.b – Covered open ridge

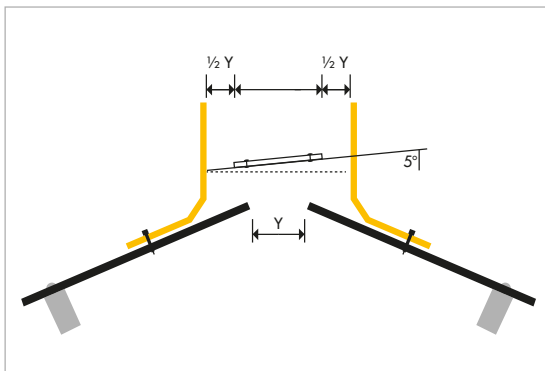
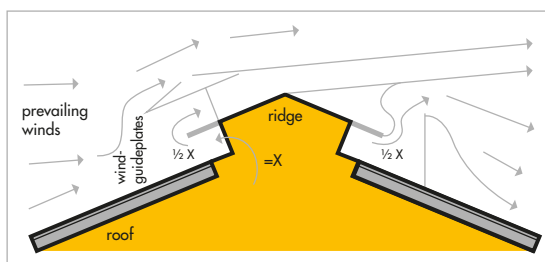

Figure 13.c – Light ridge



## Slotted roof



Slotted roofs (where the roof sheets are inverted and fitted with a space of around 10mm between each adjacent side sheet) can be very useful, particularly if considering housing during summer months. With the emergence of multi-span dairy units, spaced roofs become a necessity. It should be remembered that a spaced roof will reduce the flexibility of the building, if it was to be used without animals.

Cranked open ridges are not suitable as they only offer around 20% of the required outlet, although are still commonly fitted.

## 13.3 Inlet ventilation

The inlet area, ideally split evenly across the two side walls, should as an absolute minimum be twice the outlet area and is preferably four times the outlet area. The aim of the inlets is not to restrict airflow but to reduce airspeed at animal height. Uncontrolled air speed at animal height is only likely to be beneficial in the UK during the warm, summer months.

The aim should be, where possible, to ventilate the building from the sides. Inlet areas in the gable ends are only recommended where the building is excessively wide (>25m), or where there are restrictions in the inlet areas along one or both sides of the building.

A cladding material with many small openings is suitable for inlets in GB winter housing. The design requirement is to match the available materials with:

- the calculated optimum area of inlet for each side wall (a)
- the available area in the side wall for cladding (b)

- the degree of exposure to the weather of the side wall (c).

The example building requires an optimum of 9.4m<sup>2</sup> of inlet area in each side wall (a).

If there is 2m height between the top of a solid concrete/block wall and the eaves, in a building 27m long, the available area for cladding is 54m<sup>2</sup> (b). Therefore, approximately 20% of the cladding area must be void. The inlet area may be greater than the calculated opening as long as due consideration is given to air speed at animal height.

The required inlet area for the example building could be covered with:

- A horizontal slot of 370mm deep below the eaves and the full length of the building
- Space board (4 inch board, 1 inch gap) the full length of the building
- Yorkshire boarding (6 inch board, 1.5 inch gap) the full length of the building
- Plastic or woven cladding with at least 20% void
- Perforated metal sheeting with at least 20% void.

The first example needs to be further protected from wind penetration (such as overhanging eaves). Space boarding should not be used with a gap larger than 1 inch, otherwise wind, rain and snow may penetrate the cladding. Yorkshire boarding can be used on exposed sides of buildings; the two rows of boards are placed either side of the purlins opposite the vertical gaps between the boards.

### Yorkshire Boarding



The pitch of the roof can influence how well the stack effect is established but selecting the pitch of a roof, particularly with a span building, will always be a compromise between ventilation and overall ridge height.

#### Think about

- Roofs are normally pitched around 12.5% although examples can be seen with roof pitches of 22.5%. The building height will be significantly greater with a 22.5% pitch, this may pose issues with the planning authorities.

There are many farms installing curtain sides to the cubicle building which allow the amount of air admitted through the inlets to be varied according to prevailing weather conditions. These curtains can be lifted and raised manually or automatically and provide greater environmental control.

### Lifting side inlet ventilation



Consideration needs to be given to the prevailing wind direction when considering inlet ventilation. If there is insufficient weather protection, rain will drive into the building and result in wet cubicle beds. In addition, wind velocity may blow bedding off the beds and lead to lower cubicle occupancy in some areas due to the 'draught', this will result in an increased stocking rate in the rest of the building.

### 13.4 Protection from wind speed

The impact of wind speed can vary greatly, either from slightly reduced feed conversion ratio, to immune suppression and increased severity of disease. The principle mechanism in which air speed impacts on animal health and performance is through energy loss.

#### ! Think about

Energy loss will double when wind speed rises from 0 to 6.8m/s (15mph).

The basic rules of using windbreaks

- The purpose of a windbreak is to reduce air speed
- A badly located or poorly finished windbreak is often worse than no wind break
- The optimum porosity/permeability of a windbreak is 50%
- The minimum ratio of length to height of a windbreak is 12:1 to minimise the effect of the increased wind speed coming around the ends of the windbreak
- Wind speed will be reduced downwind of a permeable windbreak for up to 30 times the barrier height
- Support structures for windbreaks should be at approximately 3m intervals.

#### Windbreak material



The design of a successful natural ventilation system can be complex and requires consideration to be taken of the span of the building, the location of the building relative to other buildings, windbreaks, the pitch of the roof and the stocking rate.

### 13.5 Ventilation calculations

The area (size) of outlet that is required in the roof to allow heat and moisture produced from the livestock to leave the building by natural convection should be calculated first. The inlet area required in the side walls to support the natural ventilation is defined after the area of outlet is calculated.

A ventilation calculation is shown for an example building below.

Building length = **27.43m (A)**

Building width = **18.29m (B)**

Area = (B) x (A) = **502m<sup>2</sup> (C)**

Stocking density = 50 cows at 600kg **(D)**

Area per animal = 502m<sup>2</sup>(C) ÷ 50 (D)= **10m<sup>2</sup>/animal (E)**

**Refer to figure 13.d.** A floor area of 10m<sup>2</sup>/animal **(D)** at an average live weight of 600kg requires an outlet area per animal of **0.149m<sup>2</sup> (F)**

The outlet area in the roof per animal **(F)** needs to be modified by the influence of the pitch of the roof; in effect the difference in height between the eaves height and the ridge height.

Figure 13.d – Ventilation areas for cattle buildings

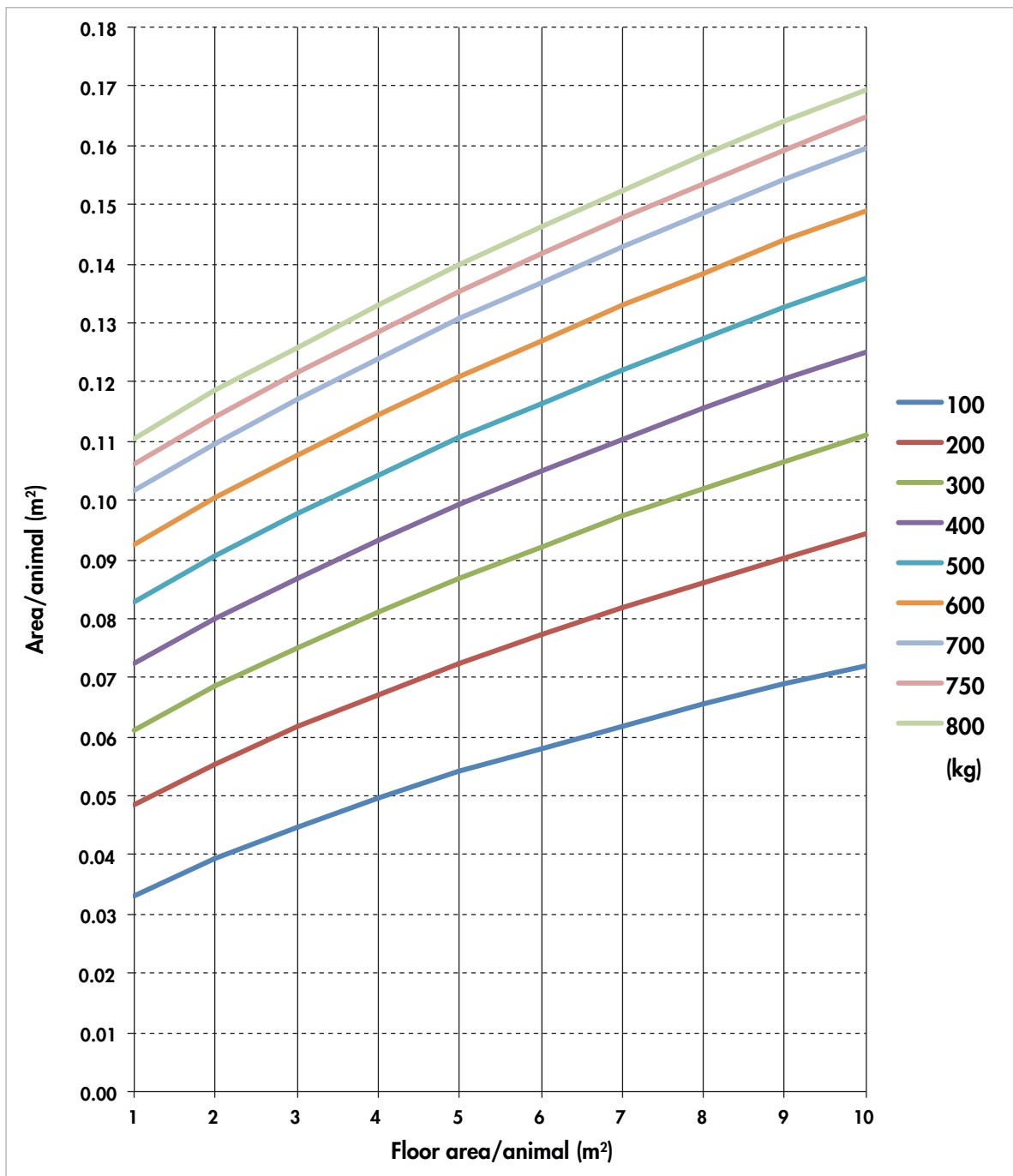

To calculate the height difference between the eaves and the ridge of a building, either measure or extract the measurement from building plans, or estimate by counting reference points in the gable ends, such as rows of blocks. An alternative is to estimate the slope of the roof and use Table 13.a.

Table 13.a

Height difference (**G**) = roof slope multiplier x half the building width (**B**)

Roof slope	Multiplier
10 degree	0.176
12 degree	0.213
15 degree	0.268
17 degree	0.306
20 degree	0.364
22 degree	0.404

For a 15° roof slope the height difference (**G**) is:

$$0.268 \times (0.5 \times 18.29 \text{ (B)}) = 2.45\text{m}$$

With a 15° pitch, the eaves to ridge height difference of the example building is therefore **2.45m (G)**

Referring to Figure 13.e, a height difference of 2.45m corresponds to a height factor for the example building of **0.63m (H)**

The actual outlet area required for this example building is:

Outlet area per animal (**F**) x height factor (**H**) x number of animals (**D**) = **Total outlet area required (I)**

Outlet area required is  $0.149 \text{ (F)} \times 0.63 \text{ (H)} \times 50 \text{ (D)}$   
= **4.69m<sup>2</sup> (I)**

### Think about

The outlet area required is a defined value; how this area is achieved in the ridge is flexible. A common solution is to provide a continuous gap along the ridge, in which case the required gap width is the outlet area required (**I**) divided by the building length (**A**). In this case the required gap is  $4.69\text{m}^2 \text{ (I)} \div 27.43 \text{ (A)} = 171\text{mm}$ . This is a precise minimum gap size; in reality it would be practical to provide a gap of 180 or 200mm.

The inlet area, ideally split evenly across the two side walls is an absolute minimum of twice the outlet area and preferably four times the outlet area.

Figure 13.e – Building height factor

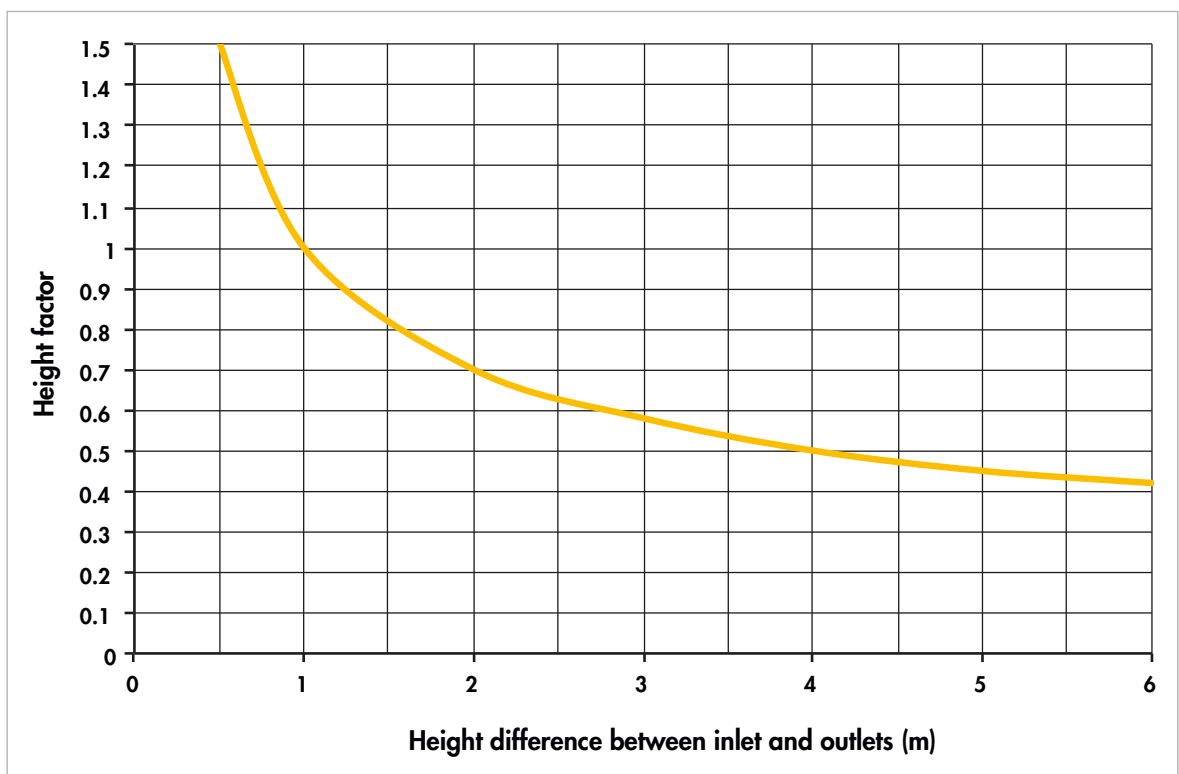

## 13.6 Mechanical ventilation

In GB, there is growing interest in the installation of fans to move volumes of air within cattle buildings. These are often described as mechanical ventilation systems. However, all they predominantly do is recirculate existing air.

There are a number of systems available for assisting the ventilation of cattle buildings, these include:

- Ventilation fans draw fresh air from outside the building and blow the fresh air down a duct with numerous small outlets along the length. The aim is to distribute clean fresh air along the length of the building, acting as a substitute for an inlet in the side wall. It is essential that a well-distributed outlet is provided in the ridge; otherwise a fan system can act as a mechanism to distribute any airborne infections throughout a building.
- Extractor fans are only effective in small areas, or in modern fully-controlled environment houses. Extractor fans can be used in small areas to extract moist air from ceiling areas with no roof outlets.
- Cooling fans increase the rate of air flow and assist the uptake and removal of heat and moisture from a surface. Cooling fans have a subsequent positive impact on animal comfort and disease risk.

Cooling fans are not a fresh air distribution system. As the air flow is forced along a building through the cattle and above the bedding and cubicle surfaces it will accumulate heat, moisture and biological aerosols.

### Think about

The high volume, low speed (HVLS) fans are large fans (between 4.8-7.5m in diameter) which revolve slowly and move large columns of air at a relatively low velocity (2.0km/hr). A 6.0m fan will typically move around 3500m<sup>3</sup>/min of air.

### Think about

A high speed (HS) fan is more compact (less than 1.0m diameter) and operates at a higher speed. Each HS fan can typically move around 600m<sup>3</sup>/min of air. An HVLS fan will cost approximately £2700 while an HS fan can be purchased for around £200. However, to move the same volume of air as an HVLS fan, six HS fans would be required.

Research teams have reported that the HVLS fans may produce a more even air movement throughout the barn. The HS fans produce higher velocities of air in the area directly surrounding the fan, leaving large areas of still air. The HVLS fans can be located 20m apart and are often located above the cubicle area.

### Think about

There are relatively few buildings which cannot be made to ventilate naturally if they are designed carefully or remedial works undertaken. The decision to resort to assisted ventilation, with increased running costs and maintenance should not be taken lightly.

The installation of fans should be seen as a response to an issue of heat stress rather than failing ventilation.

## 13.7 Heat Stress

Dairy cows need to maintain a constant body temperature of 38.8°C +/- 0.5°C. They are sensitive to factors which influence their thermal exchange with the environment. These factors are air temperature, radiant energy, air velocity and relative humidity.

When an animal becomes heat stressed, her feed intake will decline which in turn will affect her milk yield. There will also be likely to be a reduction in fertility and an increase in embryonic loss. An increase in cases of clinical mastitis is often seen in heat stressed animals.

Air temperature and radiant energy directly influence

the heat exchange ability of the animal. Air velocity increases the amount of heat transfer from the surface of the cow. Air movement can also improve evaporation, which assists in heat loss.

Relative humidity can be a problem in either the summer or the winter. In winter, it can make the animals' coats wet which reduces their insulating properties. In summer, it reduces evaporation and limits heat loss.

Research papers have suggested that, for a lactating dairy cow, there is a band of temperature at which she is most comfortable. This 'comfort zone' or 'thermoneutral zone' is between 5°C and 25°C. The objective of any dairy housing system must be to maintain this comfort zone, irrespective of season.

### ! Think about

5°C is called the Lower Critical Temperature (LCT) and 25°C is the Upper Critical Temperature (UCT). Temperatures outside of this are outside of the animals' 'comfort zone'.

At temperatures below the LCT, the cow will increase her dry matter intake to keep warm or convert feed to

heat rather than produce milk. At temperatures above the UCT, cows will sweat in an attempt to dispel the excess heat and the cow will become heat stressed. When the relative humidity increases, the UCT will fall and animals will become heat stressed more quickly.

When a cow becomes heat stressed, she will eat less feed and produce significantly less milk. As the ambient temperature increases above the UCT, milk yields can fall by as much as 20%. There is evidence that heat stress is most marked when it comes in short periods with no time for the cow to adapt to the rising temperatures.

One study in the USA examined the impact of increasing air temperature and relative humidity on milk yield. A summary of the findings are highlighted in Table 13.b. The milk yield reductions are shown as a percentage of the control.

**Table 13.b – Effects of Ambient Temperature and Relative Humidity (RH) on Milk Yield.**

Control (22°C and 40% RH)	29°C and 40% RH	29°C and 90% RH
100%	97%	67%

The Temperature – humidity index (THI) was developed by the University of Arizona and indicates the degree of stress on dairy cows. This is shown in Table 13.c.

**Table 13.c – Temperature Humidity Index (THI)**

	Relative Humidity %								
	20	30	40	50	60	70	80	90	100
22 °C	66	66	67	68	69	69	70	71	72
24 °C	68	69	70	70	71	72	73	74	75
26 °C	70	71	72	73	74	75	77	78	79
28 °C	72	73	74	76	77	78	80	81	82
30 °C	74	75	77	78	80	81	83	84	86
32 °C	76	77	79	81	83	84	86	88	90
34 °C	78	80	82	84	85	87	89	91	93
36 °C	80	82	84	86	88	90	93	95	97
38 °C	82	84	86	89	91	93	96	98	100
40 °C	84	86	89	91	94	96	99	101	104

No heat stress	Moderate heat stress	Severe heat stress	Dead cows
----------------	----------------------	--------------------	-----------



When the THI index exceeds 72, high-producing dairy cows become affected by heat stress. This level is breached and the cow can become stressed with temperatures as low as 22°C when the relative humidity is high (90%). As the humidity falls, the temperature at which the cow becomes stressed rises. When humidity is 10%, the ambient temperature needs to be 29.4°C before the cow becomes stressed.

When the THI exceeds 80, the cow is considered to be severely stressed. When the THI exceeds 100, animals will die.

### Think about

Increasing airflow over a cow has a dramatic effect on evaporative heat loss from the skin. Airflow as low as 10km/hr can reduce respiration rates in heat stressed animals by as much as 50%.

The installation of fans, combined with spraying water onto cows, can dramatically reduce the effects of heat stress.

An example of how water could be used to wet the skin of the cow:

- Cows should be wet in the feed stance with 1.5 litres of water over a period of 60 seconds followed by 4 minutes of drying with a 10km/hr airflow.

It should be noted that application of water to cows around the bedded area is likely to have implications for the dryness of the beds and, ultimately, mastitis levels. Water can be applied more easily within the collecting yard while cows wait for milking.

Benefits of wetting will be reduced unless combined with fans to increase airflow and, therefore, evaporative losses.

There is evidence of considerable benefit from providing spray cooling and assisted airflow in the tight confines of the collecting and dispersal yards. When cows are at higher stocking densities temperatures can rise rapidly.

## 13.8 Insulated roof

There is concern about the transfer of radiant energy through metal roofs in cow accommodation. When the roof is constructed from tin sheets, research in the USA has suggested that there can be a typical temperature difference of 10°C, measured on the underside of the roof, between an insulated and an uninsulated roof.

Observations from the research staff at Lelystad in Holland confirm that, during the summer months, the temperature under the roof of their high technology farm (with an insulated roof) can reach 40°C. This is compared to a temperature of 60°C under the roof of their non-insulated shed. However, this appeared to have relatively little effect on the ambient temperature within the building.

### Think about

The exterior roof colouring of the building should be considered. Light colours have reflective advantages over dark colours.

## 13.9 Roof lights

The heat at ground level of sun shining through a roof light can be around 850W/m<sup>2</sup>. This can cause considerable stress to cows if they cannot move away, such as in a collection yard. Depending on the aspect of the collection yard roof, there may be advantages of providing shade during the summer months by painting out the roof lights. It may also be advisable to limit the amount of roof lights on south-facing roofs in housing areas, while increasing the number of roof lights on the north-facing roof.

## Further reading

---

- Collier, R.J. 1982. Influences of Environment and its Modification on Dairy Animal Health and Production. *J. Dairy Sci.* 65:2213-2227.
- West, J. 2003. Effects of Heat Stress on Production of Dairy Cattle. *J. Dairy Sci.* 86:2131-2134.
- Nordlund, K. 2003. Ventilating Existing Buildings. American Assoc. of Bovine Practitioners. 36th Annual Conference, Columbus, OH.
- Bucklin, R.A. 1993. Reflective Coatings for Heat Stress Reduction in Livestock Housing. *App. Eng. Agric.* 9:123-129.